

Jablite Limited

Unit A, Rudford Industrial Estate
Ford Road
Ford
Nr Arundel
West Sussex
BN18 0BD
Tel: 01903 725282
e-mail: sales@jablrite.co.uk
website: www.jablrite.co.uk



Agrément Certificate

20/5829

Product Sheet 1

JABLITE FLOORING SYSTEMS

JABLITE THERMAL FLOOR SYSTEM INCORPORATING STRUCTURAL BOARDS

This Agrément Certificate Product Sheet⁽¹⁾ relates to the Jablrite Thermal Floor System Incorporating Structural Boards comprising precast, prestressed concrete beams; a range of expanded polystyrene (EPS) Infill Panels; EPS Structural Boards; concrete perimeter slip-bricks; and concrete closure blocks. The system is for use in conjunction with a structural concrete topping in suspended concrete ground floors in single-family dwellings, flats, communal areas in blocks of flats and other buildings within the load criteria specified within this Certificate.

(1) Hereinafter referred to as 'Certificate'.

CERTIFICATION INCLUDES:

- factors relating to compliance with Building Regulations where applicable
- factors relating to additional non-regulatory information where applicable
- independently verified technical specification
- assessment criteria and technical investigations
- design considerations
- installation guidance
- regular surveillance of production
- formal three-yearly review.

KEY FACTORS ASSESSED

Strength and stability — the system has adequate strength and stiffness to support a suitable structural concrete topping and can sustain and transmit the design dead and imposed floor loads (see section 6).

Thermal performance — the EPS products can enable a floor to meet the design U values specified in the national Building Regulations (see section 7).

Condensation risk — the system can contribute to limiting the risk of condensation (see section 8).

Durability — the system components will have a design life equivalent to that of the building in which they are incorporated (see section 10).

The BBA has awarded this Certificate to the company named above for the system described herein. This system has been assessed by the BBA as being fit for its intended use provided it is installed, used and maintained as set out in this Certificate.

On behalf of the British Board of Agrément

Date of First issue: 24 November 2020

A handwritten signature in black ink, appearing to read 'Hardy Giesler'.

Hardy Giesler
Chief Executive Officer

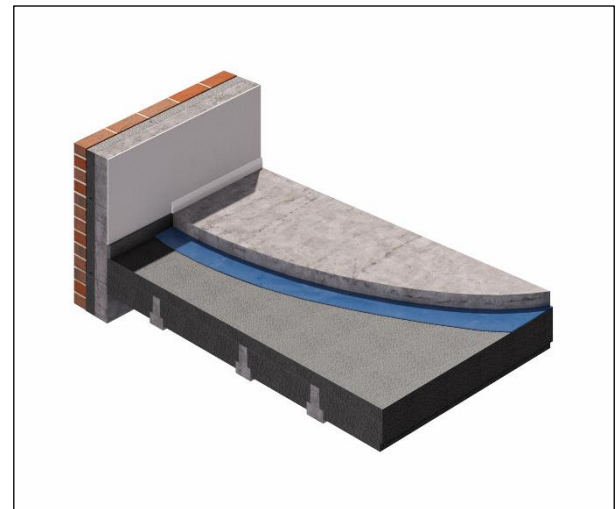

The BBA is a UKAS accredited certification body – Number 113.

The schedule of the current scope of accreditation for product certification is available in pdf format via the UKAS link on the BBA website at www.bbacerts.co.uk

Readers MUST check the validity and latest issue number of this Agrément Certificate by either referring to the BBA website or contacting the BBA directly.

Any photographs are for illustrative purposes only, do not constitute advice and should not be relied upon.

British Board of Agrément

Bucknalls Lane
Watford
Herts WD25 9BA

©2020

tel: 01923 665300
clientservices@bbacerts.co.uk
www.bbacerts.co.uk

Regulations

In the opinion of the BBA, Jablite Thermal Floor System Incorporating Structural Boards, if installed, used and maintained in accordance with this Certificate, can satisfy or contribute to satisfying the relevant requirements of the following Building Regulations (the presence of a UK map indicates that the subject is related to the Building Regulations in the region or regions of the UK depicted):



The Building Regulations 2010 (England and Wales) (as amended)

| | | |
|---------------------|-----------------|--|
| Requirement: | A1(1) | Loading |
| Comment: | | The system can sustain and transmit dead and imposed floor loads to the ground. See sections 6.2, 6.3 and 6.7 to 6.24 of this Certificate. |
| Requirement: | C2(c) | Resistance to moisture |
| Comment: | | The system can contribute to limiting the risk of surface condensation. See sections 8.1, 8.4 and 8.5 of this Certificate. |
| Requirement: | L1(a)(i) | Conservation of fuel and power |
| Comment: | | The system can contribute to satisfying this Requirement. See section 7.3 of this Certificate. |
| Regulation: | 7(1) | Materials and workmanship |
| Comment: | | The system is acceptable. See section 10 and the <i>Installation</i> part of this Certificate. |
| Regulation: | 26 | CO₂ emission rates for new buildings |
| Regulation: | 26A | Fabric energy efficiency rates for new dwellings (applicable to England only) |
| Regulation: | 26A | Primary energy consumption rates for new buildings (applicable to Wales only) |
| Regulation: | 26B | Fabric performance values for new dwellings (applicable to Wales only) |
| Comment: | | The system can contribute to satisfying these Regulations. See section 7.3 of this Certificate. |



The Building (Scotland) Regulations 2004 (as amended)

| | | |
|--------------------|-------------|---|
| Regulation: | 8(1) | Durability, workmanship and fitness of materials |
| Comment: | | The system can contribute to a construction satisfying this Regulation. See section 10 and the <i>Installation</i> part of this Certificate. |
| Regulation | 9 | Building standards in relation to construction |
| Standard: | 1.1(a)(b) | Structure |
| Comment: | | The system can sustain and transmit dead and imposed floor loads to the ground, with reference to clause 1.1.1 ⁽¹⁾ . See sections 6.2, 6.3 and 6.7 to 6.24 of this Certificate. |
| Standard: | 3.15 | Condensation |
| Comment: | | The system can contribute to limiting the risk of surface and interstitial condensation, with reference to clauses 3.15.1 ⁽¹⁾ , 3.15.4 ⁽¹⁾ and 3.15.5 ⁽¹⁾ . See sections 8.1, 8.5 and 8.6 of this Certificate. |
| Standard: | 6.1(b) | Carbon dioxide emissions |
| Comment: | | The system can contribute to satisfying of this Standard, with reference to clauses 6.1.1 ⁽¹⁾ and 6.1.6 ⁽¹⁾ . See section 7.3 of this Certificate. |
| Standard: | 6.2 | Building insulation envelope |
| Comment: | | The system can contribute to satisfying the requirements of this Standard, with reference to clauses 6.2.1 ⁽¹⁾ and 6.2.3 ⁽¹⁾ . See section 7.3 of this Certificate. |

| | | |
|-----------|--------|--|
| Standard: | 7.1(a) | Statement of sustainability |
| Comment: | | The system can contribute to satisfying the relevant Requirements of Regulation 9, Standards 1 to 6, and therefore will contribute to a construction meeting a bronze level of sustainability as defined in this Standard. In addition, the system can contribute to a construction meeting a higher level of sustainability as defined in this Standard, with reference to clauses 7.1.4 ⁽¹⁾ [Aspects 1 ⁽¹⁾ and 2 ⁽¹⁾], 7.1.6 ⁽¹⁾ [Aspects 1 ⁽¹⁾ and 2 ⁽¹⁾] and 7.1.7 ⁽¹⁾ [Aspect 1 ⁽¹⁾]. See section 7.3 of this Certificate. |

(1) Technical Handbook (Domestic).



The Building Regulations (Northern Ireland) 2012 (as amended)

| | | |
|--------------------|------------------------------|--|
| Regulation: | 23(a)(i) (iii)(b) | Fitness of materials and workmanship |
| Comment: | | The system is acceptable. See section 10 and the <i>Installation</i> part of this Certificate. |
| Regulation: | 29 | Condensation |
| Comment: | | The system can contribute to limiting the risk of interstitial condensation. See section 8.1 of this Certificate. |
| Regulation: | 30 | Stability |
| Comment: | | The system can sustain and transmit dead and imposed floor loads to the ground. See sections 6.2, 6.3 and 6.7 to 6.24 of this Certificate. |
| Regulation: | 39(a)(i) | Conservation measures |
| Regulation: | 40(2) | Target carbon dioxide emission rate |
| Comment: | | The system can contribute to satisfying these Regulations. See section 7.3 of this Certificate. |

Construction (Design and Management) Regulations 2015

Construction (Design and Management) Regulations (Northern Ireland) 2016

Information in this Certificate may assist the client, designer (including Principal Designer) and contractor (including Principal Contractor) to address their obligations under these Regulations.

See sections: 3 *Delivery and site handling* (3.6), 6 *Strength and stability* (6.4) and 14 *Procedure* (14.6, 14.7, 14.13, 14.14 and 14.19) of this Certificate.

Additional Information

NHBC Standards 2020

In the opinion of the BBA, Jablite Thermal Floor System Incorporating Structural Boards, with macro-polymer, steel fibres and steel mesh structural concrete toppings⁽¹⁾, if installed, used and maintained in accordance with this Certificate, can satisfy or contribute to satisfying the relevant requirements in relation to *NHBC Standards*, Chapter 5.2 *Suspended ground floors*.

(1) NHBC do not accept the use of micro-polymer fibre structural concrete toppings (see Table 3, footnote 9 of this Certificate).

CE marking

The Certificate holder has taken the responsibility of CE marking the EPS products in accordance with harmonised European Standards BS EN 15037-4 : 2010 and BS EN 13163 : 2012.

Technical Specification

1 Description

1.1 The Jablite Thermal Floor System Incorporating Structural Boards consists of precast, prestressed concrete beams; a range of expanded polystyrene (EPS) Infill Panels (Full, Half, Start, End and Make up); EPS Structural Boards (grey and white); concrete closure blocks; and structural concrete toppings, for use in suspended ground floors.

1.2 The Infill Panels and Structural Boards have the nominal characteristic properties and dimensions given in Table 1 and Figure 1 of this Certificate.

Table 1 Characteristic properties of the Structural Boards and Infill Panels

| Description | Overall thickness (mm) | Width | | Length (mm) | Declared level of compressive stress of EPS at 10 % deformation (kPa) | Bending strength (kPa) | Mechanical resistance according to BS EN 15037-4 : 2010 | Thermal conductivity λ_D value ($W \cdot m^{-1} \cdot K^{-1}$) and colour | Moisture diffusion coefficient (μ) |
|-------------------|--|----------|-------------|-------------|---|------------------------|---|---|--|
| | | Top (mm) | Bottom (mm) | | | | | | |
| Full Panel | 150 | 533 | 485 | 1220 | 70 | 115 | R1a | (0.038 White) (0.030 Grey) | 20 to 40 ⁽²⁾ |
| Half Panel | | 343 | 295 | | 100 | 150 | | (0.036 White) (0.030 Grey) | 30 to 70 ⁽²⁾ |
| Start Panel | | 335 | 311 | | 70 | 115 | | (0.038 White) (0.030 Grey) | 20 to 40 ⁽²⁾ |
| End Panel | | 178 | 154 | | 90 | 135 | | (0.038 White) (0.030 Grey) | 30 to 70 ⁽²⁾ |
| Make up Panels | 100 | 400 | | 2400 | 130 | 180 | — | (0.036 White) (0.030 Grey) | 30 to 70 ⁽²⁾ |
| Structural Boards | 75, 100, 120, 150, 200, 300 ⁽¹⁾ | 1200 | 1200 | | 150 | 200 | | (0.035 White) (0.030 Grey) | |
| | | | | | 200 | 250 | | (0.033 White) (0.031 Grey) | 40 to 100 ⁽²⁾ |

(1) For Structural Board thicknesses between 75 and 300 mm that are not listed in this Table, the Certificate holder should be contacted. For configuration of the maximum thickness of the Structural Boards and the minimum top flanges of concrete beams, see Table 2 of this Certificate.

(2) It is recommended that the least favourable value is used in calculations of risk of interstitial condensation (see section 8.1 of this Certificate).

Figure 1 Example Standard Infill Panels dimensions

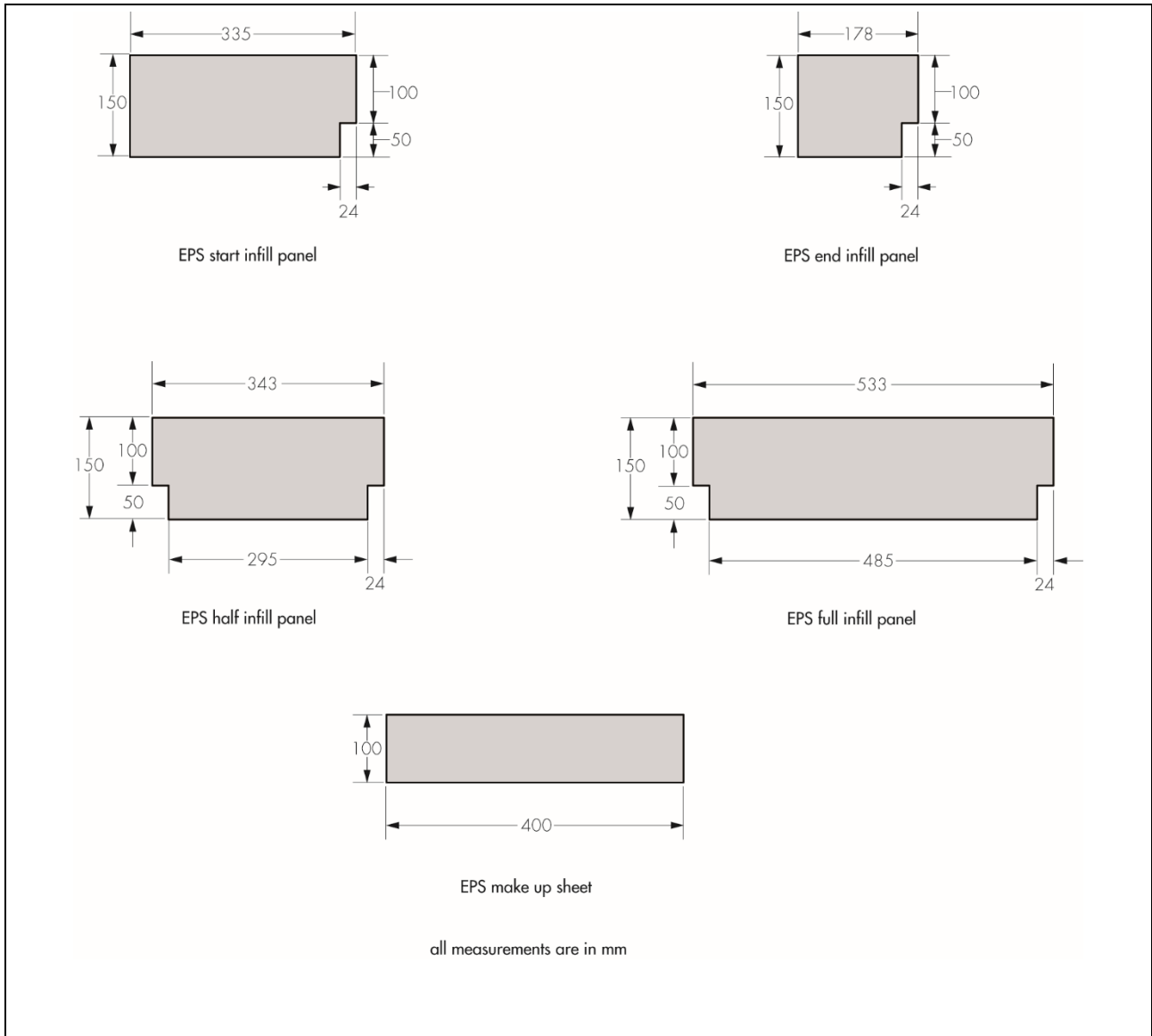

1.3 The Certificate holder's specifications for ancillary items used in conjunction with the EPS products include the following:

- prestressed concrete beams⁽¹⁾ — of the type shown in Figure 2 of this Certificate, CE marked and designed in accordance with BS EN 1992-1-1 : 2004 and its UK National Annex, BS EN 206 : 2013, BS 8500-1 : 2015 and BS 8500-2 : 2015. See sections 6.17 to 6.24 of this Certificate

Figure 2 Precast concrete beams used for thermal and full-scale tests

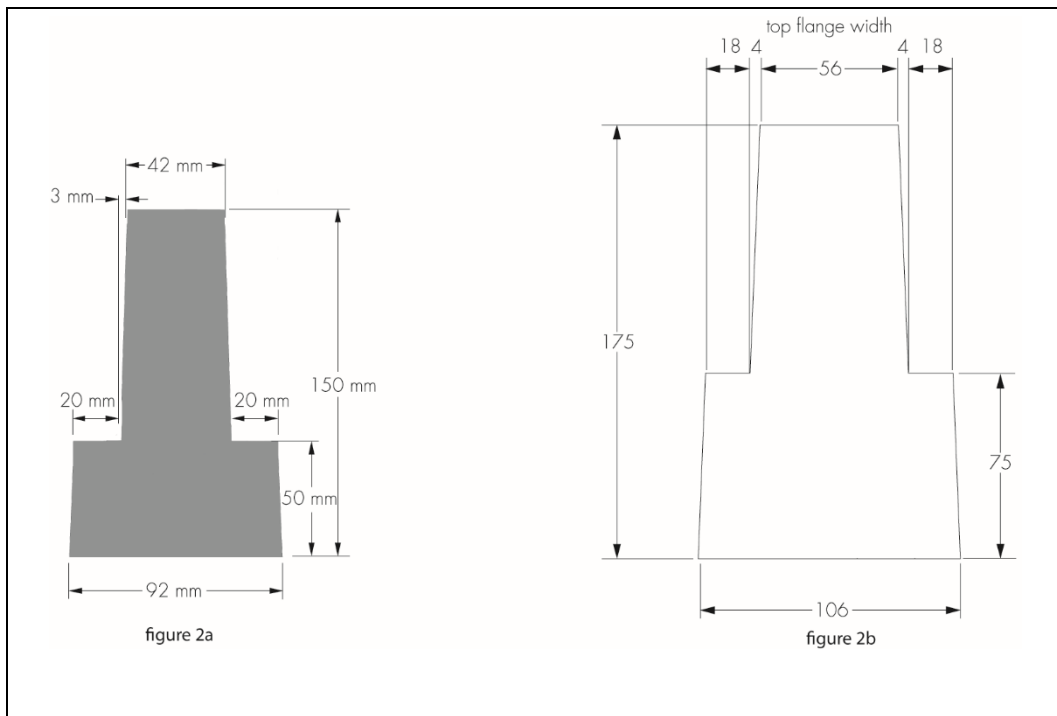

- concrete topping⁽¹⁾ reinforced with steel mesh to the specifications given in Table 3, depending on the proposed floor usage. The concrete topping reinforced with steel mesh must be designed in accordance with BS EN 1990 : 2002, BS EN 1991-1-1 : 2002 and BS EN 1992-1-1 : 2004 and their respective UK National Annexes, with a maximum aggregate size of 20 mm
- concrete topping⁽¹⁾ reinforced with macro-polymer or steel fibres, to the specifications given in Table 3 with a maximum aggregate size of 10 to 20 mm. See section 6.13 of this Certificate
- ultimate bending moment capacity of concrete topping⁽¹⁾ reinforced with polymer macro or steel fibres to the specifications given in Table 3 must be designed in accordance with TR34 fourth edition, with a maximum aggregate size of 10 to 20 mm
- concrete topping⁽¹⁾ reinforced with polymer micro fibres to the specifications given in Table 3, with a maximum aggregate size of 20 mm
- concrete closure blocks and concrete perimeter slip-bricks — with a compressive strength equal to, or greater than, that of the blocks used to form the inner leaf of the wall. For dimensions of concrete closure blocks, see Figure 3
- optional stainless steel edge clips — act as a construction aid and can contribute additional support for the Start and End Infill Panels against the applied design dead and imposed loads on the floor. The specification of the clips is shown below. For further details, see Figure 4 and section 6.10 of this Certificate:

| | |
|--------------------------|------------------------------|
| Diameter of the clip | 2.95 mm |
| Grade of stainless steel | 302 |
| Tensile / yield strength | 1470/1710 N.mm ⁻² |
| Modulus of elasticity | 187.7 kN.mm ⁻² |

- insulation strips (width 25 or 30 mm) — for perimeter of structural concrete toppings.

(1) The concrete used in the prestressed beam and concrete toppings must comply with BS EN 206 : 2013, BS 8500-1 : 2015 and BS 8500-2 : 2015.

Figure 3 Closure blocks details (measurements in mm)

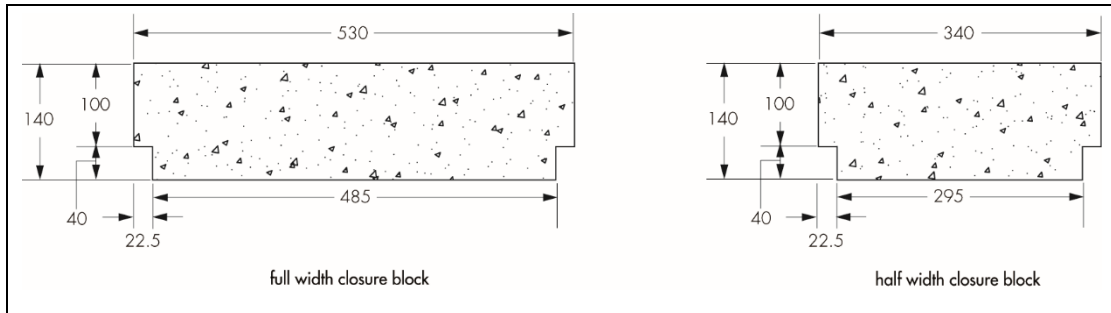
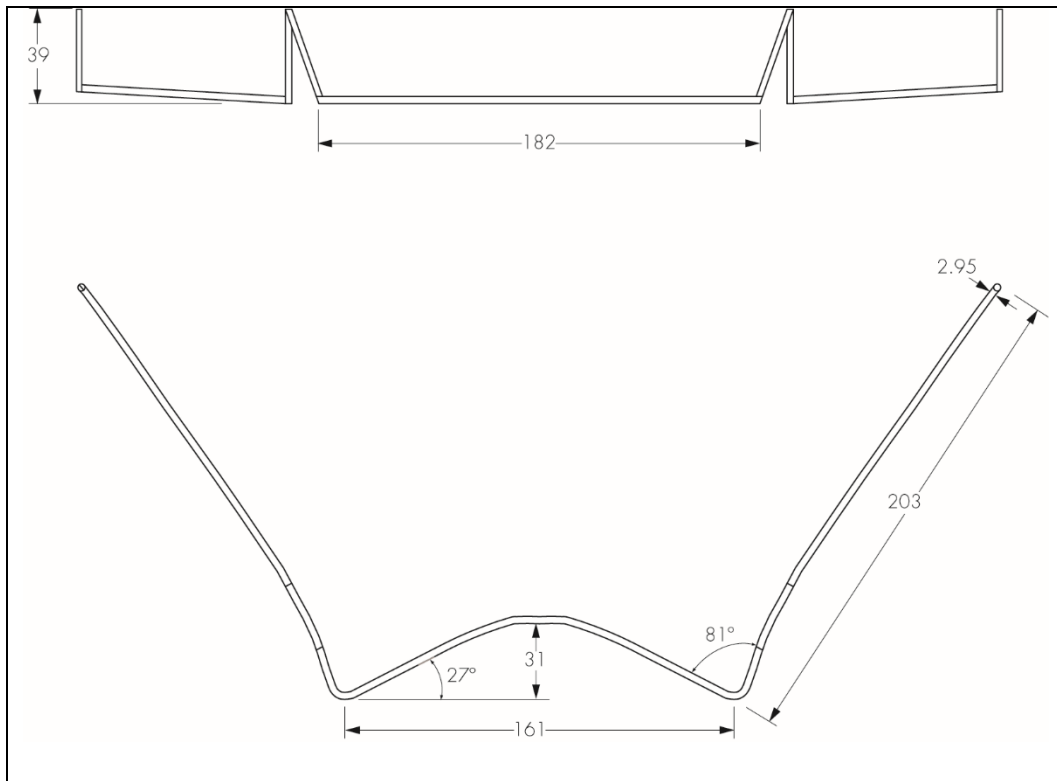

Figure 4 Stainless steel edge clips



1.4 Ancillary items outside the scope of this Certificate include:

- where required, gas barrier membranes⁽¹⁾ with third-party approval
- vapour control layer (VCL)⁽¹⁾
- damp-proof membranes (dpm)⁽¹⁾ with third-party approval

(1) must be compatible with EPS

2 Manufacture

2.1 The Structural Boards and Infill Panels are manufactured from expanded polystyrene beads using conventional moulding techniques.

2.2 As part of the assessment and ongoing surveillance of product quality, the BBA has:

- agreed with the manufacturer the quality control procedures and product testing to be undertaken
- assessed and agreed the quality control operated over batches of incoming materials
- monitored the production process and verified that it is in accordance with the documented process
- evaluated the process for management of nonconformities
- checked that equipment has been properly tested and calibrated
- undertaken to carry out the above measures on a regular basis through a surveillance process, to verify that the specifications and quality control operated by the manufacturer are being maintained.

2.3 The management system of Jablite Ltd has been assessed and registered as meeting the requirements of BS EN ISO 9001 : 2015 by CQS Ltd (Certificate GB2005746).

3 Delivery and site handling

3.1 Care must be taken when unloading, stacking and storing the concrete beams to prevent damage. They should be lifted as near as possible to each end and must remain the correct way up at all times. On site, concrete beams must be stored on timber bearers on suitably level ground.

3.2 The concrete beams should be stacked horizontally, one above the other. Timber bearers should be placed close to the beam ends (within 300 mm) and vertically aligned.

3.3 For storage periods exceeding three months, the concrete beams should be kept under cover.

3.4 The Structural Boards and Infill Panels are wrapped in polythene, but are otherwise unprotected. Therefore, reasonable care must be taken during transit and storage to avoid damage.

3.5 The Structural Boards and Infill Panels should be stacked on a flat base, clear of the ground, protected against prolonged direct sunlight and secured to avoid wind damage. Care must be taken to avoid contact with organic solvents.

3.6 The Structural Boards and Infill Panels must not be exposed to flame or ignition sources.

Assessment and Technical Investigations

The following is a summary of the assessment and technical investigations carried out on the Jablite Thermal Floor System Incorporating Structural Boards.

Design Considerations

4 Use

4.1 The Jablite Thermal Floor System Incorporating Structural Boards is suitable for use as part of a suspended ground floor (over a sub-floor void) in buildings where the loads do not exceed those specified in Table 4 of this Certificate.

4.2 A suitably experienced/qualified engineer should perform a site-specific assessment/design to ensure that:

- the Structural Boards, Infill Panels, Make Up Infill Panels, concrete beam and structural concrete topping are in accordance with the recommendations in this Certificate and the relevant parts of BS EN 15037-1 : 2008 and BS EN 15037-4 : 2010
- for concrete toppings reinforced with steel mesh, macro-polymer or steel fibres, the concrete beam meets the requirements of sections 1.3 and 6.19 to 6.24 of this Certificate
- for micro fibre concrete topping, if concrete beams other than the beam shown in Figure 2a are specified then the requirement of sections 6.18 to 6.24 of this Certificate is also satisfied
- the floor is not loaded by construction materials until the concrete topping has reached its design strength
- the natural frequency of the floor is greater than 4.0 Hz. Use of the system where vibration due to rhythmic activity (such as dancing) and external sources (eg building construction or rail traffic) may be encountered, is outside the scope of this Certificate.
- where required, lateral restraint is provided at ground floor level in accordance with the requirements of the national Building Regulations, BS 8103-1 : 2011 and *NHBC Standards* 2020.

4.3 A void of at least 150 mm deep for the system must be provided between the underside of the floor and the ground surface.

4.4 In locations where clay heave is anticipated, a greater void depth may be required to accommodate the possible expansion of the ground below the floor. In cases where the risk of clay heave has been confirmed by geotechnical investigations, a total void of up to 300 mm (refer to *NHBC Standards 2020*) may be required as follows:

- high volume change potential (300 mm total void)
- medium volume change potential (250 mm total void)
- low volume change potential (200 mm total void).

4.5 On sites which may be subject to emissions of gas or volatile organic compounds (VOCs), a suitably experienced and qualified person must assess the compatibility of the insulation with any potential emissions.

4.6 The selected structural concrete topping must be designed and installed strictly in accordance with this Certificate and the Certificate holder's instructions (see section 6.11). The dosage rate for macro-/micro-polymer and steel fibres must be in accordance with Table 3 of this Certificate.

4.7 The tolerance for the batching process and criteria for acceptability of steel and macro-/micro-polymer fibres content must be in accordance with Tables 27 and B.2 of BS EN 206 : 2013.

4.8 For macro polymer and steel fibres, the maximum allowed deviation of single test results from limit values, from tolerance on a target value or from the limits of the specified class should be in accordance with Table 22 of BS EN 206 : 2013.

4.9 Electrical cables in contact with the EPS should be enclosed in a suitable conduit. The Certificate holder should be consulted for further advice.

4.10 The system can be used in floors with suitable underfloor heating systems. Care must be taken to ensure that the minimum design thickness of structural concrete topping is maintained, eg above pipes.

5 Practicability of installation

The system is designed to be installed by a competent general builder or contractor, experienced with this type of system.

6 Strength and stability

General

6.1 A suitably experienced/qualified engineer must ensure that the concrete beams and structural concrete topping are suitable for the intended application (see section 4.2 of this Certificate).

EPS products



6.2 The Structural Boards in conjunction with the Infill Panels provide a permanent formwork for the structural concrete topping. The boards also contribute to the short- and long-term structural performance of the floor by transferring the vertical imposed and dead loads to the concrete beams.

6.3 Subject to compliance with the design and installation requirements of this Certificate, the EPS products have adequate strength to carry the normal temporary loads expected during the construction phase of the floor system, including the weight of the structural concrete topping.

6.4 The Infill Panels may be cut to accommodate varying beam lengths, but must be at least 300 mm long and should be positioned at the floor edges. The widths of the Start and End Panels are 335 mm and 178 mm respectively.

6.5 The Infill Panels are designed to have a normal bearing of 18 mm, with a 3 mm allowance for misalignment and manufacturing tolerances in the straightness of the beam, with a minimum bearing width of 15 mm.

6.6 The Make up Infill Panels (see section 14.7) should not be used at widths greater than 400 mm.



6.7 The Structural Boards have adequate resistance to short- and long-term creep compression. The strain against stress performance of the Structural Boards under the applied loads at SLS (Serviceability Limit State) conditions remains within the permitted elastic performance limit of 1.5%. The long-term thickness reduction of the Structural Boards remains within the acceptable limit of 2% after 50 years, when subjected to a permanent compressive stress of $0.3 \sigma_{10}$ (σ_{10} is the compressive stress of the EPS at 10 % deformation).

6.8 The Structural Boards must be used in conjunction with a concrete beam similar to that shown in Figures 2a and 2b of this Certificate and which has a top flange width equal to or greater than 42 or 56 mm as shown in Table 2. The conditions specified in sections 6.19 and 6.20 of this Certificate must also be met.

Table 2 Correlation between the Structural Board thicknesses and compressive stress in conjunction with beams in Figures 2a and 2b

| Structural Board thicknesses (mm) | Declared level of compressive stress at 10% (kPa) | Minimum top flange width of concrete beam (mm) |
|--|--|---|
| 75 to 120 | 130 | 56 |
| 75 to 300 | 150 | 42 |
| 75 to 300 | 200 | 42 |

6.9 Spacers for supporting steel mesh reinforcement should be located on spreader plates over the Structural Boards. This will reduce the risk of accidental penetration of the EPS during the construction phase and any resulting misalignment of the reinforcement within the structural concrete topping depth.

Stainless steel edge clips

6.10 The optional stainless steel edge clips, if present, act as a construction aid and can contribute additional support for the Start and End Infill Panels against the applied design dead and imposed loads on the floor at SLS and ULS (Ultimate Limit Space) conditions (see section 1.3 of this Certificate). Three clips are used per full length of Start and End Infill Panels, and one clip is used per minimum cut length of Start and End Infill Panels.

Structural concrete toppings

6.11 For loadings defined in Table 4 of this Certificate, the concrete topping thickness and reinforcement specification must be as shown in Table 3. The concrete topping above the Start and End Panels must be designed as a cantilevered slab and must not exceed 178 and 335 mm respectively (see Figure 6).

6.12 The structural concrete topping should be in accordance with BS 8500-1 : 2015, BS 8500-2 : 2015 and BS EN 206 : 2013, manufactured in plants covered by the QSRMC scheme (Quality Scheme for Ready Mixed Concrete) and laid by personnel with the appropriate skills and experience.

6.13 The structural concrete topping specifications shown in Table 3, in conjunction with the Infill Panels specified in Table 1 and Figure 1, and the concrete beams defined in section 1.3, are suitable for use in buildings as specified in each bullet point below. (The characteristic loads are defined in Table 4). This has been confirmed by:

- calculation to BS EN 1992-1-1 : 2004 and its UK National Annex for steel mesh reinforcement, thickness and strength class of concrete topping⁽¹⁾ — see concrete reference no. 1 of Table 3 of this Certificate. For characteristic loads associated with single-family dwellings, communal areas in blocks of flats and other buildings of a similar nature
- full scale test for adequacy of macro-polymer fibre concrete topping — see concrete reference no. 2 in Table 3. For characteristic loads associated with single-family dwellings, communal areas in blocks of flats and other buildings of a similar nature
- test, and structural calculation [in accordance with 'equation 6' of TR34 (fourth edition, March 2016)] of the ultimate bending moment capacity of a 65 mm concrete topping⁽¹⁾ reinforced with macro-polymer or steel fibres — see concrete references nos. 3 to 6 of Table 3. For characteristic loads associated with single-family dwellings

- full scale test for adequacy of micro-polymer fibre⁽²⁾ concrete topping (concrete reference no. 7 in Table 3) and other acceptable micro⁽²⁾ polymer fibres (as shown in Table 3). For characteristic loads associated with single-family dwellings. (For concrete beams, refer sections 6. 18 to 6.24 of this Certificate)
- full scale test for adequacy of macro-polymer fibre concrete topping — see concrete reference nos 9 and 10 in Table 3. For characteristic loads associated with single-family dwellings.

(1) The concrete topping above the Start and End Panels must be designed as a cantilever slab and must not exceed 178 mm and 335 mm respectively (see Figure 1 and section 6.4 of this Certificate).

(2) Micro-polymer-fibre-only structural concrete toppings are not accepted on NHBC sites.

Table 3 Specification and thickness of structural concrete toppings⁽¹⁾⁽²⁾

| Ref no. | Reinforcement | Load category | | Method of verification |
|---------|--|------------------------|--|--------------------------------------|
| | | Single-family dwelling | Communal areas in blocks of flats or other similar buildings | |
| 1 | One layer of A142 mesh to BS 4483 : 2005 with a characteristic yield strength (f_{yk}) of 500 N·mm ⁻² . Reinforcement should be placed at mid height of the concrete slab. | 65 mm | 75 mm | Calculation to BS EN 1992-1-1 : 2004 |
| 2 | Durus S400 ⁽⁶⁾ (macro-polymer fibre), dosage rate 4.0 kg·m ⁻³ , 45 mm long, 0.9 mm diameter, tensile strength 465 N·mm ⁻² and modulus of elasticity 3350 N·mm ⁻² | 75 mm | | Full-scale test |
| | | 65 mm | | Structural calculations |
| 3 | Novomesh B&BA ⁽⁷⁾⁽⁸⁾ (steel fibre), dosage rate 17.50 kg·m ⁻³ , steel flat end, steel fibres, fibre length 50 mm, diameter 1.0 mm, tensile strength 1150 N·mm ⁻² | 65 mm | — | Calculation to TR34 |
| 4 | Novomesh B&BA ⁽⁶⁾⁽⁷⁾ (macro-polymer and micro polyolefin fibre), dosage rate 3.84 kg·m ⁻³ , shape of macro fibre: continuously deformed, 60 mm long, 0.56 mm diameter, tensile strength 600 N·mm ⁻² , modulus of elasticity 7000 N·mm ⁻² | | — | Calculation to TR34 |
| 5 | Adfil SF86 ⁽⁷⁾⁽⁸⁾ (steel fibre), dosage rate 13.33 kg·m ⁻³ , 60 mm long, diameter 0.75 mm, tensile strength 1225 N·mm ⁻² , modulus of elasticity 200000 N·mm ⁻² | | — | Calculation to TR34 |
| 6 | Durus Easy Finish ⁽⁶⁾⁽⁷⁾ (macro-polymer fibre), dosage rate 3.00 kg·m ⁻³ , 40 mm long, 0.7 mm equivalent diameter, tensile strength 470 N·mm ⁻² , modulus of elasticity 6000 N·mm ⁻² | | — | Calculation to TR34 |
| 7 | Fibrin X-T ⁽⁹⁾ (monofilament polypropylene micro fibre), minimum dosage rate 0.91 kg·m ⁻³ , 12 mm long, 22 microns diameter, tensile strength 280 N·mm ⁻² | | — | Full-scale test |
| 8 | Fibrin 23 ⁽⁹⁾ (polypropylene micro fibre), dosage rate 0.90 kg·m ⁻³ to 0.91 kg·m ⁻³ , 12 mm long, 19.5 microns diameter, tensile strength 312 N·mm ⁻² | | — | Full-scale test |
| 9 | Nexus 85 (macro-polymer fibre) dosage rate 2.5 kg·m ⁻³ , 60 mm long, 0.7 mm diameter, tensile strength 375 N·mm ⁻² and modulus of elasticity 5000 N·mm ⁻² | | — | Full-scale test |
| 10 | Zenith 60 (steel fibre), dosage rate 10 kg·m ⁻³ , 60 mm long, diameter 1.0 mm, tensile strength 1500 N·mm ⁻² , modulus of elasticity 200000 N·mm ⁻² | | — | Full-scale test |

- (1) The overall depth of concrete topping above the services is 65 or 75 mm
- (2) All of the fibres in Table 3 can be used within a C28/35 standard concrete (see note 3, below) with maximum 20 mm aggregate (see note 5, below) or C28/35 self-compacting concrete (see note 4, below) with maximum 10 mm aggregate (see note 5, below). Steel fibres must be in accordance with BS EN 14889-1 : 2006 and polymer fibres must be in accordance with BS EN 14889-2 : 2006
- (3) For standard concrete, the slump should be Class S3 (100 to 150 mm) or S4 (for spot samples taken from initial discharge, 140 to 230 mm)
- (4) For self-compacting concrete, the slump flow class should be SF1 (550 to 650 mm) or SF2 (660 to 750 mm). The sand content should be greater than 45%
- (5) The aggregate for concrete must comply with BS EN 12620 : 2002
- (6) For fresh concrete, macro-polymer fibre content should be measured in accordance with BS EN 14488-7 : 2007
- (7) The dosage rates of steel and polymer fibres defined in this Table include 15% additional fibres and are designed to give the minimum required residual flexural tensile strength of concrete toppings with steel and macro-polymer fibres. See also section 6.13 of this Certificate.
- (8) For fresh and hardened concrete, steel fibre content should be measured in accordance with BS EN 14721 : 2005.
- (9) Micro-polymer-fibre-only structural concrete toppings are not accepted on NHBC sites.

6.14 Permitted characteristic loadings for structural concrete toppings reinforced with macro-polymer fibres, steel mesh and micro-polymer fibres are shown in Table 4 of this Certificate.

Table 4 Maximum characteristic imposed, partition loads and weight of finishes for structural concrete toppings reinforced with macro- or micro-polymer-fibres or steel mesh A142

| Description | Maximum characteristic loads for single-family dwellings (min. 65 mm thickness) | Maximum characteristic loads for communal areas in blocks of flats or other suitable buildings (min. 75 mm thickness) |
|--|---|---|
| | | |
| Imposed concentrated load (kN) | 2.0 ⁽¹⁾⁽²⁾ | 4.0 ⁽¹⁾⁽²⁾ |
| Line load partition parallel and perpendicular to the beam ($\text{kN}\cdot\text{m}^{-1}$) | 1.0 ⁽³⁾ | 3.0 ⁽³⁾ |
| Allowance for moveable partition ($\text{kN}\cdot\text{m}^{-2}$) | 1.0 ⁽³⁾ | 1.0 ⁽³⁾ |
| Finishes ($\text{kN}\cdot\text{m}^{-2}$) | | 0.5 |

(1) Imposed concentrated load must not be combined with the imposed UDL or other variable actions.

(2) Imposed concentrated load is assumed to be applied over a square plate not less than 100 by 100 mm.

(3) Moveable partition must not be combined with line load partition wall.

6.15 The maximum length of the cantilevered slab from the top face of the concrete beam is 335 mm (see Figure 6 of this Certificate).

6.16 The maximum distance of the concentrated load applied on the cantilever from the top face of the concrete beam is 243 mm ($335^{(1)} - 42^{(2)} - 50^{(3)} = 243$).

(1) Length of cantilever slab (see Figure 6).

(2) Width of plasterboard, skirting board and skim.

(3) Half of width of a 100 mm square plate (imposed concentrated load for residential buildings is assumed to be applied over a square plate not less than 100 by 100 mm).

Prestressed concrete beam

6.17 The Structural Boards and Start, End, Half, Full Panels and Make-up Infill Panels are for use with self-bearing prestressed concrete beams (normal weight concrete), which provide the final strength of the floor system independently of any other constituent part of the floor system.

6.18 The dimensions and specification of the prestressed concrete beams used in the full-scale structural tests are shown in Figure 2 and Table 5 of this Certificate.

Table 5 Properties of the concrete beams used for full-scale test

| Property | Value | |
|---|----------------|--|
| | Beam Figure 2a | Beam Figure 2b |
| Characteristic compressive strength of the concrete beam at 28 days — (f_{ck}) cylinder ($\text{N}\cdot\text{mm}^{-2}$) according to DoP for each concrete beam | 55 | 50 |
| Area of concrete (mm^2) | 9000 | 13725 |
| Secant modulus of elasticity of concrete (E_{cm}) ($\text{N}\cdot\text{mm}^{-2}$) | 38214 | 37277 |
| Second moment of area (I) (mm^4) | 17,028,000 | 34,493,000 |
| Aggregate | Granite | Carboniferous limestone and quartzite sand |
| Number of 5 mm diameter wires ⁽¹⁾ | 4 | 5 |
| Characteristic tensile strength of prestressing steel (f_{pk}) ($\text{N}\cdot\text{mm}^{-2}$) | 1770 | 1770 |
| Characteristic tensile strength 0.1% proof stress of prestressing steel ($f_{p0.1k}$) ($\text{N}\cdot\text{mm}^{-2}$) | 1556 | 1520 |
| Service moment resistance ($\text{kN}\cdot\text{m}$) | 5.46 | 7.483 |
| Ultimate moment resistance ($\text{kN}\cdot\text{m}$) | 7.34 | 11.819 |
| Ultimate shear resistance (kN) | 12.20 | 21.648 |
| Initial pre-stress force (kN) | 104.24 | 121.61 |
| Pre-stress force after losses (kN) | 73.56 | 90.58 |
| Eccentricity (mm) | 21.90 | 24.56 |
| Weight of beam per metre ($\text{kg}\cdot\text{m}^{-1}$) | 22.94 | 34.98 |

(1) The indented prestressing steel wire must be in accordance with BS 5896 : 2012.

6.19 The natural frequency of the concrete beam used in the test assemblies is greater than 4 Hz, as defined below. A suitably experienced/qualified engineer must ensure the following criteria are met for other floors under the specified loading conditions ⁽¹⁾:

- (a) The concrete beam should have a natural frequency greater than 4 Hz when loaded with full dead load plus 0.1 x imposed load (UDL).
- (b) The natural frequency of a simply supported concrete beam under UDL loading is determined from either equation A or B, shown below:

Equation A : $f = 18/\delta^{0.5}$

Equation B : $f = \pi/2(EI/mL^4)^{0.5}$

Where:

δ is the deflection of the concrete beam in mm for UDL.

EI is the dynamic flexural rigidity of the member (Nm²).

m is the effective mass supported by the concrete beam loaded in kg·m⁻².

L is the span of the member (m).

(1) The vibration due to rhythmic activity (such as dancing) and external sources (such as building construction or rail traffic) must be excluded from the beam and block floor systems.

6.20 Other prestressed concrete beams (other than those used for full scale tests – see Figure 2) are acceptable alternatives if a suitably experienced/qualified engineer confirms that the following conditions for the tested beam are met:

- the prestressed concrete beams must be designed in accordance with BS EN 1992-1-1 : 2004 (Eurocode 2) and its UK National Annex, by an appropriately qualified engineer to ensure that the beams are adequate to resist the applied loading
- the proposed prestressed concrete beams must be CE marked and manufactured and designed in accordance with requirements of BS EN 15037-1 : 2008
- the correlation between the compressive stress at 10% and the thickness of the Structural Boards and the top flange of the concrete beams must be in accordance with Table 2 of this Certificate
- the serviceability deflection limit of the proposed concrete beams must be in accordance with BS EN 1992-1-1 : 2004, as summarised in Table 6 of this Certificate.

Table 6 Deflection limitation of prestressed concrete beams

| Description | Limit for deflection |
|---|----------------------|
| Camber at transfer (upward deflection) of pre-stressed force under the self-weight of the beam | span/250 |
| Deflection at application of finishes – downward from the level of the bearings | span/250 |
| Deflection for long-term quasi permanent loading (M_{QP}) ⁽¹⁾ after losses in pre-stress force and creep measured from below the level of the bearings | span/250 |
| Movement after application of finishes – increase in deflection due to pre-stress loss and creep | span/500 |

(1) M_{QP} is the moment under the quasi-permanent load combination (refer to equation 6.16a of BS EN 1990 : 2002).

- the deflection of the proposed prestressed concrete beam for the same length and loads at each stage (defined in Table 6 of this Certificate) is equal to or less than the concrete beam shown in Figure 2a
- the value of E_{cm} for limestone and sandstone aggregates should be reduced by 10% and 30% respectively
- the natural frequency of the concrete beam is greater than 4 Hz, as defined in section 6.19 for floor vibration
- the concrete beam is self-bearing and no account should be made for possible composite action between the beams and the Infill Panels or the structural concrete topping
- the maximum length of the cantilevered slab from the top face of the concrete beam does not exceed 335 mm
- the maximum distance of the concentrated load applied on the cantilever load from the top face of the beam must not exceed 243 mm (335–42–50 = 243)
- the imposed loads (UDL and concentrated load) must be in accordance with BS EN 1991-1-1 : 2002 and its UK National Annex, and not exceeding the values shown in the Table 4 of this Certificate
- the minimum bearing width to support the concrete beam is 90 mm.

6.21 The maximum effective span of the concrete beam (assumed to be a simply supported and self-bearing beam) must be calculated using the equations from BS EN 1990 : 2002 (6.10 and 6.14a, or the less favourable equations, 6.10a, 6.10b and 6.14a). The lowest effective span obtained from these equations will be considered to be the maximum effective span of the concrete beam.

6.22 Concrete or grout may be required between multiple beams where composite action for loading is required. The project structural engineer should assess each floor design on a case-by-case basis to establish specific requirements.

6.23 The minimum bearing width to support the concrete beam is 90 mm in accordance with BS 8103-1 : 2011.

6.24 The concrete beam is self-bearing and no account should be made for possible composite action between the beams and the Structural Boards or the structural concrete topping.

7 Thermal performance

7.1 The overall floor U value will depend significantly on the deck U value, the ratio of the exposed (and semi-exposed) floor perimeter length to floor area (p/a), the amount of underfloor ventilation and the ground thermal conductivity. Each floor U value, therefore, should be calculated to BS EN ISO 13370 : 2017 and BRE Report BR 443 : 2019.

7.2 A floor deck U value (from inside to the underfloor void) will depend significantly on the types and number of concrete beams, Infill Panels and Structural Boards. The thermal resistance of each concrete beam and configuration should be numerically modelled to BS EN ISO 10211 : 2017 and BS EN 15037-4 : 2010. The floor deck U value may then be taken as an area-weighted average and the overall floor U value calculated as described in section 7.1.



7.3 Example floor U values given in Table 7, for a typical floor construction as shown in Figure 5, indicate that the system can enable a floor to meet, or improve upon, design floor U values of between 0.13 and 0.25 $W \cdot m^{-2} \cdot K^{-1}$, as specified in the documents supporting the national Building Regulations.

Table 7 Example floor U values⁽¹⁾⁽³⁾ for single beam configurations⁽²⁾ ($W \cdot m^{-2} \cdot K^{-1}$)

| Beam option | p/a ratio | EPS 130 Structural Boards | | EPS 150 Structural Boards | | | EPS 200 Structural Boards | |
|--------------------|------------------|----------------------------|----------------------------|------------------------------|------------------------------|----------------------------|----------------------------|----------------------------|
| | | M·m ² | — | — | 75 mm grey ⁽⁴⁾⁽⁵⁾ | 75 mm white ⁽³⁾ | 150 mm grey ⁽⁴⁾ | 75 mm white ⁽³⁾ |
| Beam 42 x 150 mm | 0.4 | — | — | 0.14 | 0.16 | 0.10 | 0.16 | 0.070 |
| Refer to Figure 2a | 0.6 | — | — | 0.15 | 0.17 | 0.11 | 0.16 | 0.071 |
| | 0.7 | — | — | 0.15 | 0.17 | 0.11 | 0.17 | 0.072 |
| | 0.9 | — | — | 0.15 | 0.17 | 0.11 | 0.17 | 0.073 |
| | M·m ² | 75 mm white ⁽³⁾ | 120 mm grey ⁽⁴⁾ | 75 mm grey ⁽⁴⁾⁽⁵⁾ | 75 mm white ⁽³⁾ | 200 mm grey ⁽⁴⁾ | 75 mm white ⁽³⁾ | 300 mm grey ⁽⁴⁾ |
| Beam 56 x 175 mm | 0.4 | 0.17 | 0.12 | — | 0.16 | 0.089 | 0.16 | 0.070 |
| Refer to Figure 2b | 0.6 | 0.18 | 0.12 | — | 0.17 | 0.092 | 0.17 | 0.072 |
| | 0.7 | 0.18 | 0.12 | — | 0.18 | 0.093 | 0.17 | 0.073 |
| | 0.9 | 0.18 | 0.13 | — | 0.18 | 0.095 | 0.18 | 0.074 |

- (1) These calculations are in accordance with sections 7.1 and 7.2 and assume:
- the T-beam λ is $2.0 W \cdot m^{-1} \cdot K^{-1}$ and 75 mm concrete screed λ is $1.15 W \cdot m^{-1} \cdot K^{-1}$
 - a 300 mm thick perimeter wall with a U value of $0.35 W \cdot m^{-2} \cdot K^{-1}$
 - underfloor ventilation area is $0.0015 m^2 \cdot m^{-1}$
 - ground conductivity is $1.5 W \cdot m^{-1} \cdot K^{-1}$
 - all other parameters are default values from BRE Report BR 443 : 2019.

(2) Configuration used – 100% single beams at full centres.

(3) Infill panel is EPS 70 (white).

(4) Infill panel is EPS 70 high performance (grey).

(5) Floor deck thickness is 300 mm (see Figure 5).

Figure 5 Typical floor construction for U value calculation

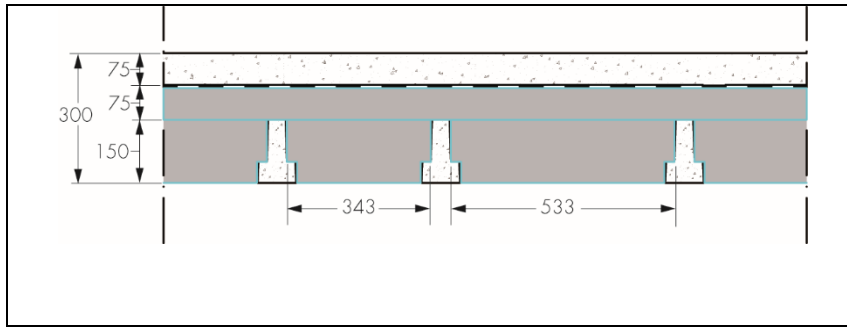

Junction ψ -values

7.4 Care must be taken in the overall design and construction of junctions between the floor and external, internal and party walls, to limit excessive heat loss and air infiltration.

7.5 The junction ψ -values given in Table 8 may be used in SAP calculations or values can be modelled in accordance with the requirements and guidance in BRE Report BR 497 : 2016, BRE Information Paper IP 1/06 and the provisions in the documents supporting the national Building Regulations relating to competency to perform calculations, determine robustness of design/construction and limiting heat loss by air infiltration.

Table 8 Junction ψ values

| Junction | ψ ($\text{W}\cdot\text{m}^{-1}\cdot\text{K}^{-1}$) |
|-------------------|---|
| External wall | |
| • Figure 6 | 0.057 ⁽¹⁾ |
| • Other junctions | 0.32 ⁽²⁾ |
| Party wall | 0.16 ⁽²⁾ |

(1) Value correct for junction shown in Figure 6 for 175 mm beams parallel to wall and for 175 mm beams perpendicular to the wall.

(2) Conservative defaults from SAP 2012.

Figure 6 Example junction construction

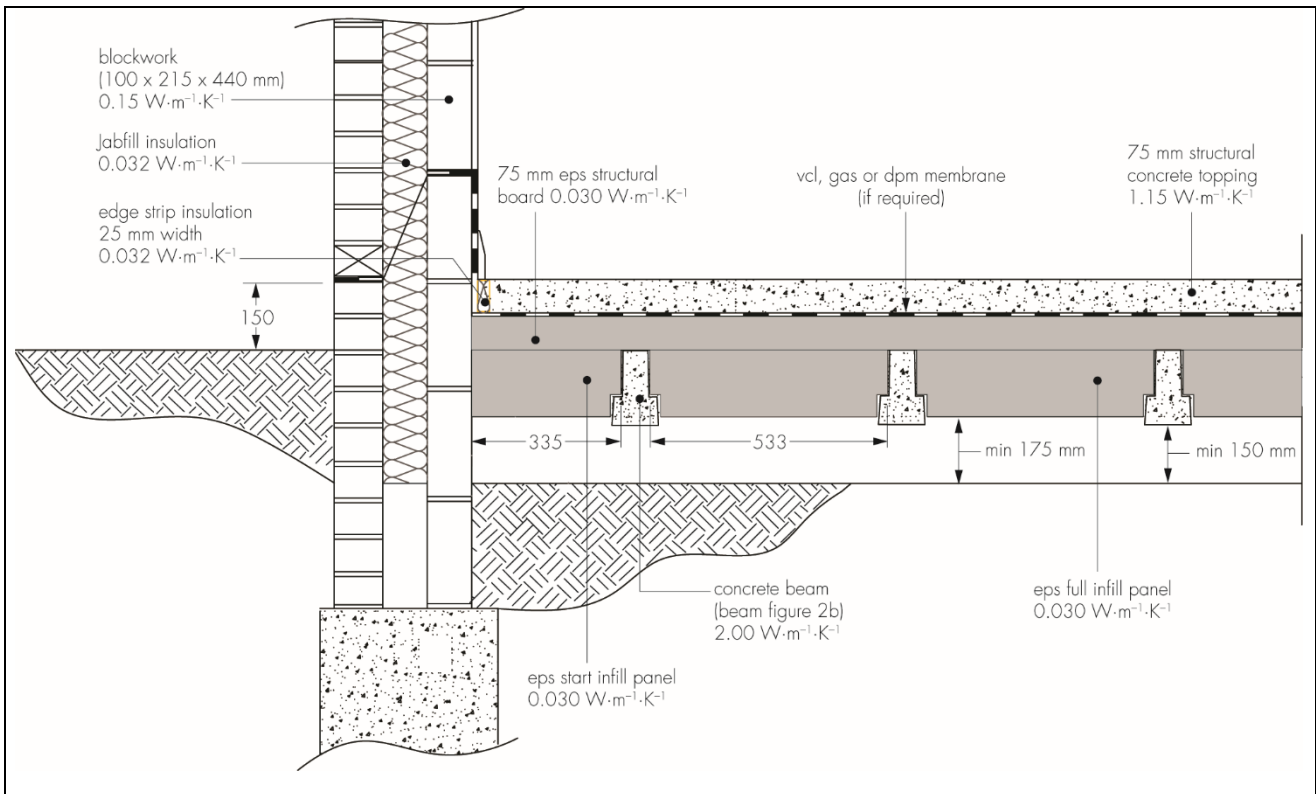

8 Condensation risk

Interstitial condensation



8.1 When there is no gas membrane, dpm or VCL located above the Structural Boards, there is a risk of interstitial condensation forming on the concrete beam or any VCL laid over the beam, which may be persistent. Therefore, the risk for each case should be assessed, both through the beam and through the insulation, in accordance with BS EN ISO 13788 : 2012 and BS 5250 : 2011, Annex D.3, accounting for the slab construction, dwelling humidity class, dwelling type and dwelling location and use of any VCL, dpm and/or gas membranes.

8.2 To help minimise the risk of condensation, the void space beneath the lowest point of the floor construction should be at least 150 mm high, with provision for adequate through-ventilation in the form of ventilation openings provided in two opposing external walls. The ventilation openings should be sized at not less than $1500 \text{ mm}^2 \cdot \text{m}^{-1}$ run of external wall or $500 \text{ mm}^2 \cdot \text{m}^{-2}$ of floor area, whichever is greater. Where pipes are used to carry ventilating air, these should be at least 100 mm diameter.

8.3 To minimise the risk of interstitial condensation at junctions with external walls, specifiers should ensure that wall insulation extends to at least 150 mm below the bottom of the Infill Panel.

Surface condensation



8.4 Floors will adequately limit the risk of surface condensation when the thermal transmittance (U value) does not exceed $0.7 \text{ W} \cdot \text{m}^{-2} \cdot \text{K}^{-1}$ at any point and the junctions with walls are in accordance with the relevant requirements of *Limiting thermal bridging and air leakage : Robust construction details for dwellings and similar buildings* TSO 2002 or BRE Information Paper IP 1/06.



8.5 The example construction described in section 7.5 was used to model a 3D corner which achieved a temperature factor of 0.90, which equals or improves upon all of the critical temperature factors, f_{CRsi} , detailed in tables 1 and 2 of BRE Information Paper IP 1/06.



8.6 Floors will adequately limit the risk of surface condensation when the thermal transmittance (U value) does not exceed $1.2 \text{ W} \cdot \text{m}^{-2} \cdot \text{K}^{-1}$ at any point and the floor is designed and constructed to BS 5250 : 2011. Additional guidance can be found in BRE Report BR 262 : 2002.

8.7 To minimise the risk of surface condensation at service penetrations, care should be taken to minimise gaps in the insulation layer.

9 Maintenance

The system components are installed within the floor structure and, therefore, do not require maintenance.

10 Durability



10.1 The EPS products are protected in service from organic solvents and substances liable to cause deterioration and will be effective as insulation for the life of the building in which they are installed (taken as 60 years).

10.2 The exposure condition beneath a suspended ground floor over a ventilated void and soil is class XC3, in accordance with BS EN 1992-1-1 : 2004. The concrete beam must have adequate durability for this exposure condition, for a design life of not less than 60 years.

10.3 The durability of the concrete topping reinforced with macro-/micro-polymer or steel fibre will be at least equivalent to that of plain concrete of the same grade.

10.4 The concrete topping reinforced with steel mesh will have adequate durability for exposure class XC1, for a design life of not less than 60 years.

10.5 The stainless steel clips will not be impaired by contact with conventional mortar admixtures or cavity insulation materials and should have a service life of not less than 60 years.

11 Reuse and recyclability

EPS material can be recycled if free from debris and contamination. The concrete and reinforcement steel can also be recycled.

Installation

12 General

Details of typical precast concrete beams and EPS block assemblies using Jablite EPS Panels are shown in Figure 7.

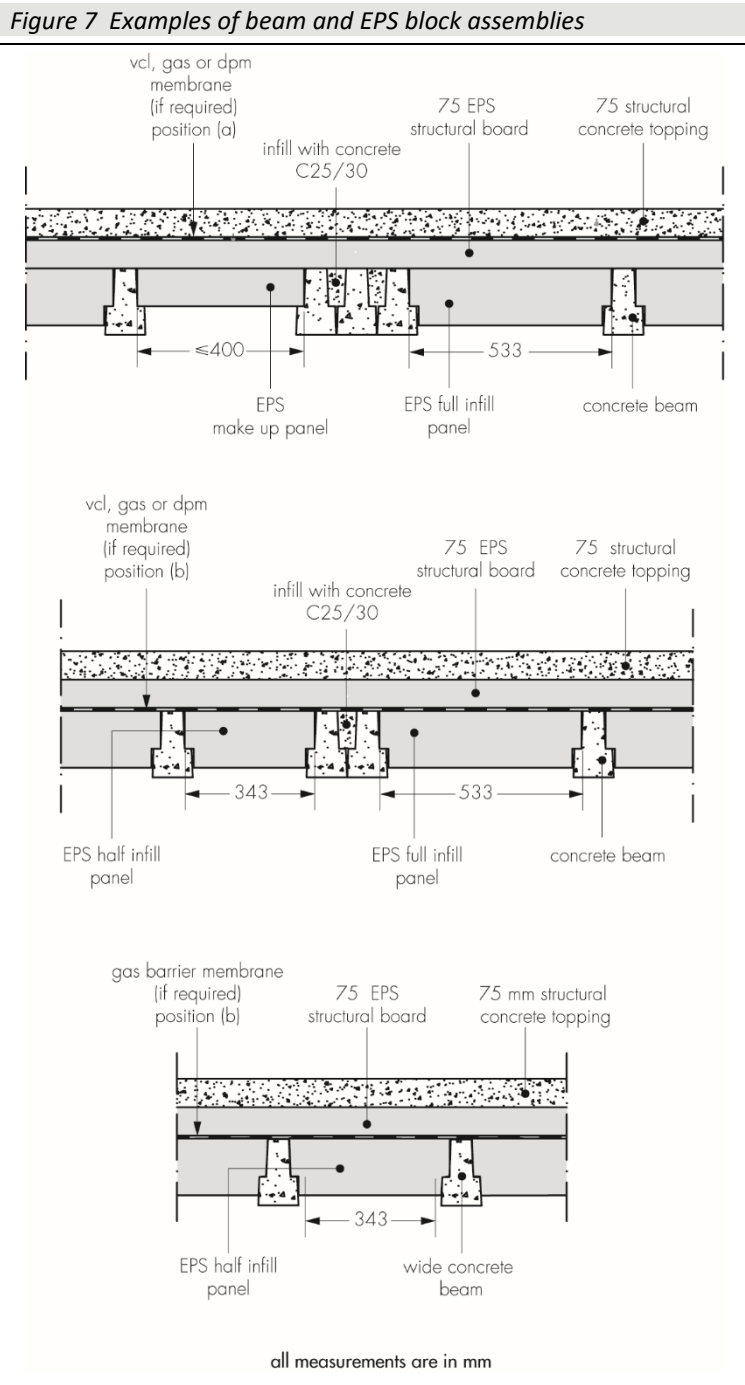

13 Site preparation

13.1 Where clay soil of low-, medium- or high-volume change potential exists, the final minimum void depth should be increased appropriately to prevent problems associated with heave (see section 4.4). The sub-floor void should have good natural drainage or land drains should be provided to prevent standing water within the sub-floor void when this is below external ground level.

13.2 The ground beneath the floor should be free of topsoil and vegetation. Oversite concrete or other surface seal is not required, but material added to bring the solum to an even surface must be hard and dry.

13.3 Damp-proofing and ventilation arrangements must be in accordance with normal good practice (for example, by the provision of damp-proof sleeves to ventilators and adequate drainage of the sub-floor).

13.4 A continuous damp proof course (dpc) should be laid along the supporting wall below the beam and block bearings in accordance with BS 8102 : 2009.

13.5 The beams are laid in the positions shown on the floor plan. Each beam is tightly placed against the beam spacing blocks. Further installation details are given in section 14 of this Certificate.

14 Procedure

14.1 Normal precautions for handling EPS materials should be taken to avoid damaging the products during offloading, storage, handling and installation. Any damaged products must be replaced before pouring the concrete.

14.2 A dpc should be laid on top of the bearing and end walls.

14.3 The precast concrete beams are positioned at approximate locations and centres shown on the Jablite approved drawing.

14.4 Start panels are attached to the first beam. The beams and panels are then positioned tightly against the wall. The stainless steel clips may be used to support the Start and End Infill Panels. The clips should be installed horizontally and in the plane of the mortar joint across a cavity. For the number of clips, see section 6.10 of this Certificate.

14.5 The remaining beams must be accurately positioned in line with the Jablite approved layout drawing using the spacer/closure blocks. The spacer/closure blocks are bedded in mortar.

14.6 The panels can be cut with a handsaw where required. Offcuts greater than 300 mm may be used elsewhere in the floor zone.

14.7 Make up Infill Panels can be used to accommodate the gaps in non-standard beam spacings. These are cut to suit on site as per the approved drawing. Make up Infill Panels (between the beams) should not be more than 400 mm wide.

14.8 Finally, the End Infill Panels incorporating stainless steel clips, if desired, are installed to complete the infill installation.

14.9 A gas membrane, VCL or dpm can be installed where required between the uppermost layers of insulation and the concrete topping or between the infill panels and the structural boards.

14.10 If gas carassing or underfloor heating pipes are specified, these can be secured to the uppermost layer of insulation material. If a gas membrane, VCL or dpm is not required, this can be achieved using standard pipe clips secured directly to the insulation. If a gas membrane, VCL or dpm is required it is advisable to install between the infill panels and the Structural Boards. Alternatively, pipes should be taped securely in position. Care must be taken not to puncture the gas membrane, VCL or dpm.

14.11 If required, perimeter edge insulation strips (thermal resistance $\geq 0.75 \text{ m}^2 \cdot \text{K} \cdot \text{W}^{-1}$) are installed against the perimeter wall.

14.12 If steel mesh is specified, spacers should be positioned over spreader plates, minimum four per m² and minimum 50 by 50 mm. These should be installed to position the steel mesh at the correct level.

14.13 The EPS panels are cut as appropriate to accommodate service penetrations, eg soil vent pipes, and the resulting gaps filled with expanding foam or other insulation to minimise local cold bridging and air infiltration.

14.14 Should any other cutting be required, the advice of the Certificate holder should be sought.

14.15 Although they can withstand light foot traffic (see section 6.2), care should still be taken not to walk unnecessarily over the installed EPS panels. If a temporary working platform is required, the panels should be covered with a suitably rigid board. To avoid damage to the panels, the structural concrete topping should be laid as soon as possible after the panels have been installed.

14.16 When using a concrete pump, truck or skip, concrete should not be discharged onto the polystyrene panels from heights greater than 500 mm and concrete heaps must not be formed over 300 mm high.

14.17 When wheelbarrows are used, planks must be placed to spread the wheel load to the precast concrete beams. Spot boards must be used when tipping and shovelling.

14.18 The structural concrete topping is placed and compacted. Provision should be made for a suitable concrete finish to be achieved, preferably by operatives not standing on the panels or boards, eg by the use of a self-levelling concrete topping.

14.19 Throughout the installation process, due consideration must be given to relevant health and safety regulations and the Certificate holder's product information sheets.

14.20 To prevent concrete ingress where a VCL, gas membrane or dpm is not placed above the Structural Boards, the procedure described below should be followed:

- the joints between the Structural Boards, or around service openings, should be taped with a minimum width of 75 mm, and/or
- any gaps between Structural Boards or around service openings, visible prior to installing the concrete, must be filled with either expanding foam or strips of insulation.

14.21 The following good practice should be taken into account throughout the installation process:

- cube compressive strength and slump tests for concrete topping
- limitation of slump for standard concrete and slump flow for self-compacting concrete
- concrete topping not to be poured below 5°C
- the maximum temperature at which the concrete should be placed is 30°C and decreasing
- concrete should not be poured during rainfall
- all the ingredients including the fibres should be added at the plant mixer.

To prevent shrinkage cracks:

- joints should be incorporated into the slab and appropriate joints between the opening of two adjacent rooms provided. Inclusion of joints must not compromise structural performance of the concrete topping
- where internal walls are built through the slab, a joint should be formed across the door threshold where the wall separates the two rooms
- an aspect ratio greater than 2:1 should be avoided
- a compressible insulating material around the perimeter of the plot to be provided
- the use of high shrinkage potential aggregate should be avoided
- the water/cement (w/c) ratio should not be increased beyond the limits specified in BS 8500-1 : 2015, BS 8500-2 : 2015 and BS EN 206 : 2013
- steel mesh or loose bars should be placed across re-entrant corners and any openings greater than 500 x 500 mm
- consideration should be given to the provision of an appropriate detail (eg crack inducer) on external walls at the position of porches.

15 Tests

15.1 A series of full-scale tests was carried out to ensure the compatibility of the structural concrete topping with the maximum deflection of the concrete beams under service and ultimate loads. The tests were designed to create the maximum curvature of the beam using the macro-/micro-polymer-fibre and steel-reinforced concrete toppings.

15.2 Full scale tests were carried out to ensure that the short-term strain of the Structural Boards under the applied loads remains within the permitted elastic performance limit of 1.5%.

15.3 Prism tests were carried out in accordance with BS EN 14651 : 2005 for steel and macro-polymer fibres.

15.4 A series of tests was carried out to assess the adequacy of stainless steel edge clips against construction loads on the Start and End Infill Panels.

15.5 Tests were conducted on the system and the results assessed to determine:

- resistance to construction loads
- thermal conductivity (λ_D values)
- dimensional accuracy.

15.6 The practicability of installation and detailing techniques was assessed.

16 Investigations

16.1 Evaluation and calculations were made of existing data to assess:

- adequacy of concrete topping reinforced with steel mesh in terms of thickness, strength class of concrete and diameter of steel reinforcement in accordance with BS EN 1992-1-1 : 2004 and BS EN 15037-1 : 2008
- adequacy of ultimate bending moment capacities of concrete toppings reinforced with steel and polymer-macro fibres in accordance with TR34 (fourth edition) against ultimate applied loads on the floor
- adequacy of long-term thickness reduction of the Structural Boards against acceptable limit of 2% after 50 years, when subjected to a permanent compressive stress of $0.3 \sigma_{10}$ (σ_{10} is the compressive stress of the EPS at 10 % deformation) was examined
- the durability, practicability of installation and detailing techniques of the system.

16.2 Floor deck U values were derived by modelling to BS EN ISO 10211 : 2017 and BS EN 15037-4 : 2010 Annex F, and example floor U values calculated to BS EN ISO 13370 : 2017.

16.3 The risk of condensation was determined in accordance with BS 5250 : 2011.

16.4 The linear thermal transmittance (Ψ value) and minimum temperature factor were modelled in accordance with BS EN ISO 10211 : 2017 and BRE Report BR 497 : 2016 for an example junction detail.

16.5 The manufacturing processes for the EPS products were evaluated, including the methods adopted for quality control, and details were obtained of the quality and composition of the materials used.

Bibliography

- BRE Information Paper IP 1/06 *Assessing the effects of thermal bridging at junctions and around openings*
- BRE Report (BR 262 : 2002) *Thermal insulation : avoiding risks*
- BRE Report (BR 443 : 2019) *Conventions for U-value calculations*
- BRE Report (BR 497 : 2016) *Conventions for calculating linear thermal transmittance and temperature factors*
- BS 4483 : 2005 *Steel fabric for the reinforcement of concrete — Specification*
- BS 5250 : 2011 + A1 : 2016 *Code of practice for control of condensation in buildings*
- BS 5896 : 2012 *High tensile steel wire and strand for the prestressing of concrete — Specification*
- BS 8102 : 2009 *Code of practice for protection of below ground structures against water from the ground*
- BS 8103-1 : 2011 *Structural design of low-rise buildings ground structures against water from investigation, foundations, precast concrete floors and ground floor slabs for housing*
- BS 8500-1 : 2015 + A2 : 2019 *Concrete — Complementary British Standard to BS EN 206-1 — Method of specifying and guidance for the specifier*
- BS 8500-2 : 2015 + A2 : 2019 *Concrete — Complementary British Standard to BS EN 206-1 — Specification for constituent materials and concrete*
- BS EN 206 : 2013 + A1 : 2016 *Concrete — Specification, performance, production and conformity*
- BS EN 1990 : 2002 + A1 : 2005 *Eurocode : Basis of structural design*
NA to BS EN 1990 : 2002 + A1 : 2005 *UK National Annex to Eurocode : Basis of structural design*
- BS EN 1991-1-1 : 2002 *Eurocode 1 : Actions on structures — General Actions — Densities, self-weight, imposed loads for buildings*
NA to BS EN 1991-1-1 : 2002 *UK National Annex to Eurocode 1 : Actions on structures — General Actions — Densities, self-weight, imposed loads for buildings*
- BS EN 1992-1-1 : 2004 + A1 : 2014 *Design of concrete structures — General rules and rules for buildings*
NA to BS EN 1992-1-1 : 2004 + A1 : 2014 *UK National Annex to Eurocode 2 : Design of concrete structures — General rules and rules for buildings*
- BS EN 12620 : 2002 + A1 : 2008 *Aggregates for concrete*
- BS EN 13163 : 2012 + A2 : 2016 *Thermal insulation products for buildings — Factory made expanded polystyrene (EPS) products — Specification*
- BS EN 14721 : 2005 + A1 : 2007 *Test method for metallic fibre concrete — Measuring the fibre content in fresh and hardened concrete*
- BS EN 14488-7 : 2006 *Testing sprayed concrete — Fibre content of fibre reinforced concrete*
- BS EN 14651 : 2005 + A1 : 2007 *Test method for metallic fibre concrete — Measuring the flexural tensile strength (limit of proportionality (LOP), residual)*
- BS EN 14889-1 : 2006 *Fibres for concrete — Steel fibres — Definitions, specifications and conformity*
BS EN 14889-2 : 2006 *Fibres for concrete — Polymer fibres — Definitions, specifications and conformity*
- BS EN 15037-1 : 2008 *Precast concrete products — Beam-and-block floor systems — Beams*

BS EN 15037-4 : 2010 + A1 : 2013 *Precast concrete products — Beam-and-block floor systems — Expanded polystyrene blocks*

BS EN ISO 9001 : 2015 *Quality management systems — Requirements*

BS EN ISO 10211 : 2017 *Thermal bridges in building construction — Heat flows and surface temperatures — Detailed calculations*

BS EN ISO 13370 : 2017 *Thermal performance of buildings — Heat transfer via the ground — Calculation methods*

BS EN ISO 13788 : 2012 *Hygrothermal performance of building components and building elements — Internal surface temperature to avoid critical surface humidity and interstitial condensation — Calculation methods (ISO13788:2012)*

TR34, 4th Edition March 2016 *Concrete Industrial Floors — A guide to design and construction*

TSO 2002 : *Limiting thermal bridging and air leakage : Robust construction details for dwellings and similar buildings*

17 Conditions

17.1 This Certificate:

- relates only to the product/system that is named and described on the front page
- is issued only to the company, firm, organisation or person named on the front page – no other company, firm, organisation or person may hold or claim that this Certificate has been issued to them
- is valid only within the UK
- has to be read, considered and used as a whole document – it may be misleading and will be incomplete to be selective
- is copyright of the BBA
- is subject to English Law.

17.2 Publications, documents, specifications, legislation, regulations, standards and the like referenced in this Certificate are those that were current and/or deemed relevant by the BBA at the date of issue or reissue of this Certificate.

17.3 This Certificate will remain valid for an unlimited period provided that the product/system and its manufacture and/or fabrication, including all related and relevant parts and processes thereof:

- are maintained at or above the levels which have been assessed and found to be satisfactory by the BBA
- continue to be checked as and when deemed appropriate by the BBA under arrangements that it will determine
- are reviewed by the BBA as and when it considers appropriate.

17.4 The BBA has used due skill, care and diligence in preparing this Certificate, but no warranty is provided.

17.5 In issuing this Certificate the BBA is not responsible and is excluded from any liability to any company, firm, organisation or person, for any matters arising directly or indirectly from:

- the presence or absence of any patent, intellectual property or similar rights subsisting in the product/system or any other product/system
- the right of the Certificate holder to manufacture, supply, install, maintain or market the product/system
- actual installations of the product/system, including their nature, design, methods, performance, workmanship and maintenance
- any works and constructions in which the product/system is installed, including their nature, design, methods, performance, workmanship and maintenance
- any loss or damage, including personal injury, howsoever caused by the product/system, including its manufacture, supply, installation, use, maintenance and removal
- any claims by the manufacturer relating to CE marking.

17.6 Any information relating to the manufacture, supply, installation, use, maintenance and removal of this product/system which is contained or referred to in this Certificate is the minimum required to be met when the product/system is manufactured, supplied, installed, used, maintained and removed. It does not purport in any way to restate the requirements of the Health and Safety at Work etc. Act 1974, or of any other statutory, common law or other duty which may exist at the date of issue or reissue of this Certificate; nor is conformity with such information to be taken as satisfying the requirements of the 1974 Act or of any statutory, common law or other duty of care.